



PROFESSIONAL SHOW LIGHTING

GOLDEN SCAN 3

HMI 575
HMI 1200
HMI 1200 TV

Congratulations on choosing a Clay Paky product! We thank you for your custom. Please note that this product, as all the others in the rich Clay Paky range, has been designed and made with total quality to ensure excellent performance and best meet your expectations and requirements.

INSTRUCTIONS MANUAL

Carefully read this instructions manual in its entirety and keep it safe for future reference.

It is essential to know the information and comply with the instructions given in this manual in order to ensure the fitting is installed, used and serviced correctly and safely.

CLAY PAKY S.p.A. disclaims all liability for damage to the fitting or to other property or persons deriving from installation, use and maintenance that have not been carried out in conformity with this instructions manual, which must always accompany the fitting.

CLAY PAKY S.p.A. reserves the right to modify the characteristics stated in this instructions manual at any time and without prior notice.

1

SAFETY INFORMATION

• Installation

Make sure all the parts for fixing the projector are in a good state of repair. Make sure the point of anchorage is stable before positioning the projector. The safety rope, properly hooked onto the fitting and secured to the framework, must be installed so that, if the primary support system fails, the fitting falls as little as possible. If the safety rope gets used, it needs to be replaced with a genuine spare.

• Minimum distance from target objects

The projector must be positioned in such a way that objects struck by the beam are separated from the lens at least by the distance indicated on the lamp change label against the symbol shown alongside.

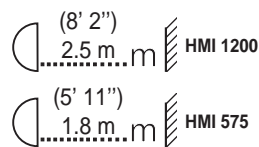

• Minimum distance of flammable materials

The projector must be positioned so that any flammable materials are at least 0,1 meter (4") for HMI 1200 and 0,07 meter (3") for HMI 575 from every point on the surface of the fitting.



It is permissible to mount the fitting on normally flammable surfaces.

• Maximum ambient temperature

For the fitting to operate well and reliably, the ambient temperature should not exceed 35°C (95°F).

• IP20 protection rating

The fitting is protected against penetration by solid bodies of over 12mm (0.5") in diameter (first digit 2), but not against dripping water, rain, splashes or jets of water (second digit 0).

• Protection against electrical shock

This fitting is classified in accordance with the type of protection against electrical shock, in **Class I**. It must therefore be connected to a power supply system with efficient earthing.

It is however recommended to protect the supply lines of the projectors from indirect contact and/or shorting to earth by using appropriately sized residual current devices.

• Connecting to the supply mains

Connection to the electricity mains must be carried out by a qualified electrical installer.

Check that the mains frequency and voltage correspond to the frequency and voltage stated on the electrical data label for which the projector is designed.

This label also gives the input power. Refer to this to evaluate the maximum number of fittings to connect to the electricity supply in order to avoid overloading.

• Maintenance

Before starting any maintenance work or cleaning the projector, cut off power from the mains supply.

After switching off, do not remove any parts of the fitting for 10 minutes.

After this time the likelihood of the lamp exploding is virtually null. If it is necessary to replace the lamp, wait for another 15 minutes to avoid getting burnt.

The fitting is designed to hold in any splinters produced by a lamp exploding. The lenses must be fitted and, if visibly damaged, they have to be replaced with genuine spares.

• Temperature of the external surface

The maximum temperature that can be reached on the external surface of the fitting, in a thermally steady state, is 90°C (194°F).

• Lamp



The projector mounts a high-pressure lamp that needs an external igniter. This igniter is fitted onto the projector.

- Carefully read the "operating instructions" provided by the lamp manufacturer.
- Immediately replace the lamp if damaged or deformed by heat.



The products referred to in this manual conform to the European Community Directives to which they are subject:

- Low Voltage 73/23
- Electromagnetic Compatibility 89/336

• Unpacking

Open the box from the top, take all the accessories out of the box and remove the polystyrene containing structures.

Open the plastic bag, remove the projector from the box frame and position it on a horizontal top where access is easy to carry out the following preliminary work.

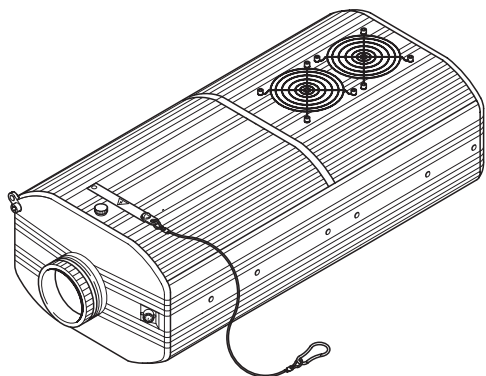

• Packing contents

Besides the projector, the packing also contains the following accessories:

- This instructions manual code 099406 (1).

- 2 spacers code 167002/001 (2).

- 1 right bracket support plate code 167003/001 (3).

- 1 left bracket support plate code 167003/002 (4).

- 2 eyebolts M8x20mm code 167004/001 (5).

- 2 nuts M8 code 020106/006 (6).

- 2 knobs code 020502 (7).

- 2 plane washers $\varnothing 10,5\text{mm}$ code 020210/004 (8).

- 1 bracket code 101011/001 (9).

- 4 bracket bushings code 101014/001 (10).

- 4 countersunk washers code 080606/001 (11).

- 4 countersunk head screws M8x20mm code 020005/001 (12).

- 1 Allen wrench 5 mm code 050001 (13).

- 4 handles code 082017/001 (14) (only for TV version).

- 8 screws TCEI M8x20 code 020002/029 (15).

- Multilingual label (16) with safety information code 081948/003 (located in the projector lampholder compartment).

- 1 safety ropes code 105041/001 (17).

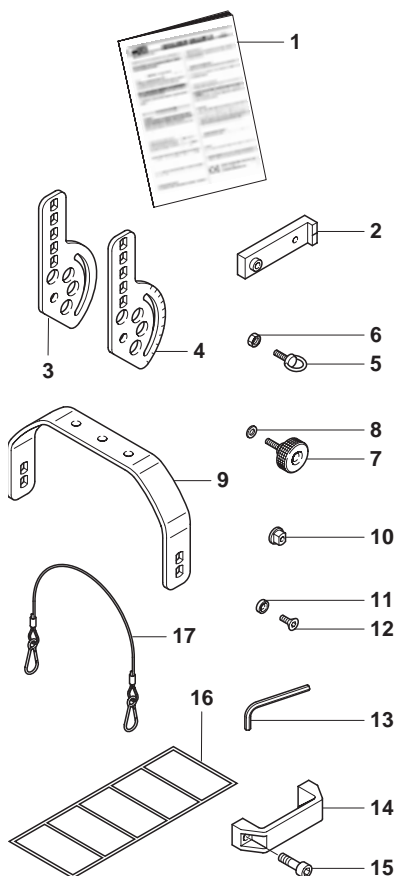

• Fitting the bracket

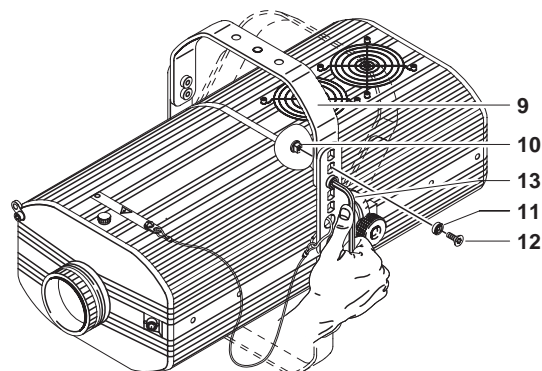
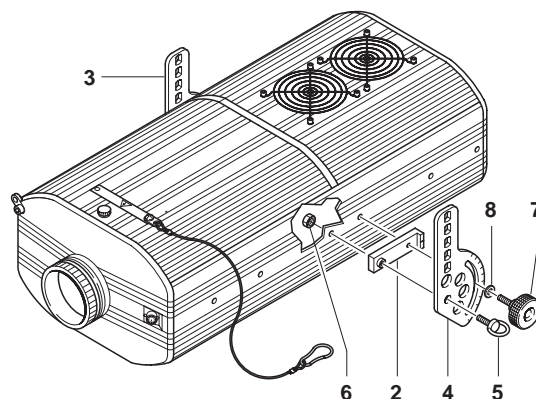

• Fitting the handles (only for TV version)

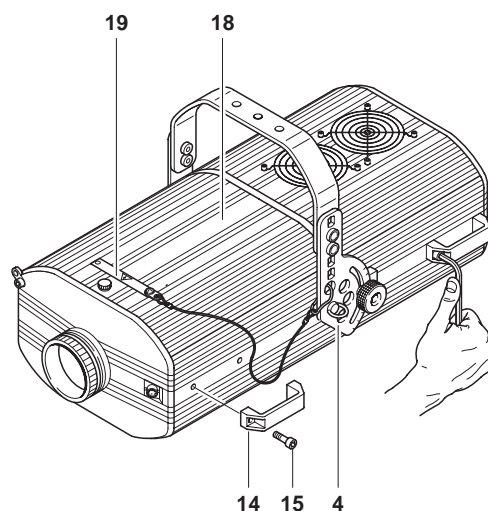

• Preparing the warning label

Find the warning label (19) on the re-lamping cover (18) and, if necessary, replace it with one of the optional multilingual labels (16) located in the projector lamp compartment. For the instructions on opening the projector, read paragraph 4 MAINTENANCE.

CAUTION: Read carefully and meticulously apply the information and instructions given on this label. In addition, check it is never removed as it contains important safety information.

• Fitting the lamp

Refer to the instructions for opening the projector and changing the lamp in paragraph 4 MAINTENANCE.

3 INSTALLATION AND FINE-TUNING

• Installing the projector

The projector can be installed on the ceiling or on a wall through the holes in the bracket. It is recommended to use 2 screws $\varnothing 12\text{mm}$ with nut and spring washer.

CAUTION: Check the plates (3 and 4) are correctly secured to the sides of the fitting; if the plates has been removed, to carry out non-routine maintenance work, reposition them, following the relevant instructions and checking the threads in the projector sides hold properly.

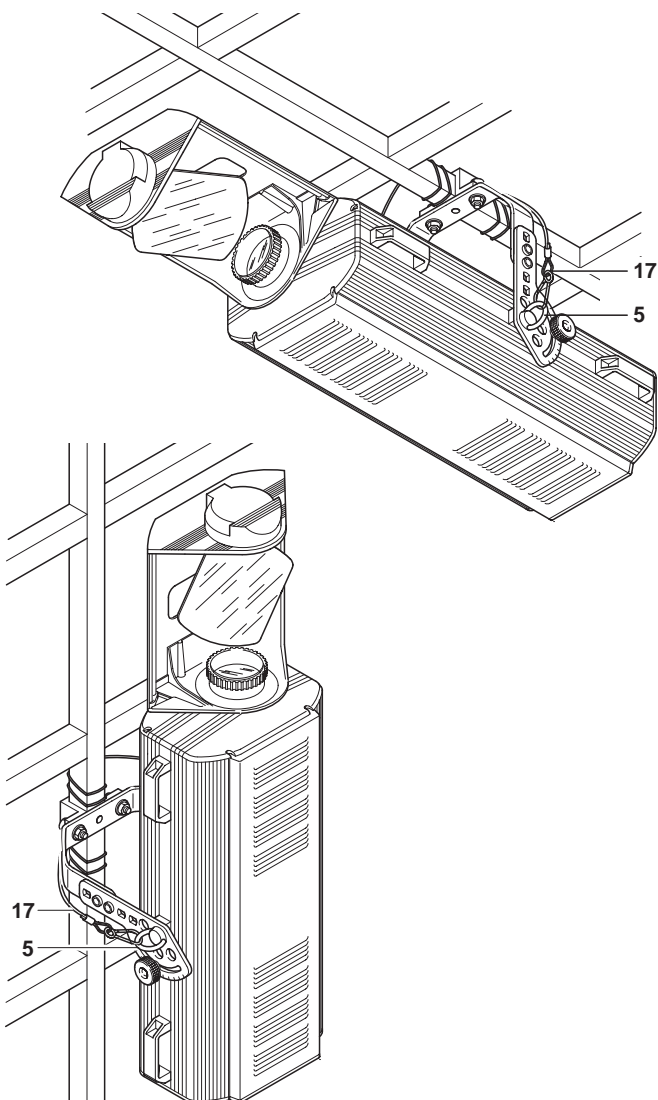

• Securing the safety ropes

Except for when the projector is standing on the floor, it is compulsory to fit the safety rope (17). These need to be secured to the projector framework and then hooked onto the eyebolts (5) screwed into the sides of the projector

• Adjusting the projector position

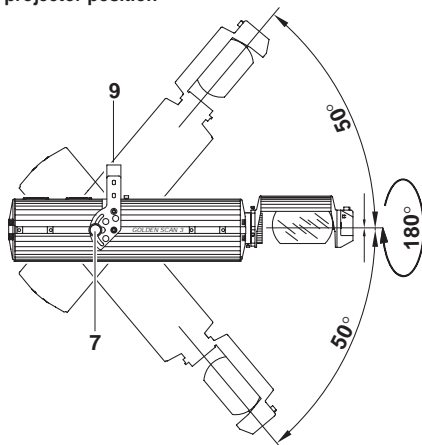

• Adjusting the lens

Slightly unscrew the knob (20) and move the lens (21) until the projected image is perfectly focused, then tighten the knob (20).

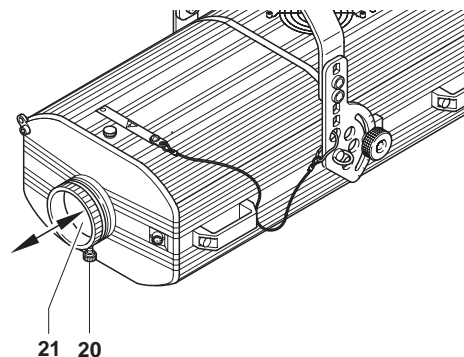

• Mains power connection

It is advisable to connect each projector via its own switch so as to be able to switch it on and off individually from a distance.

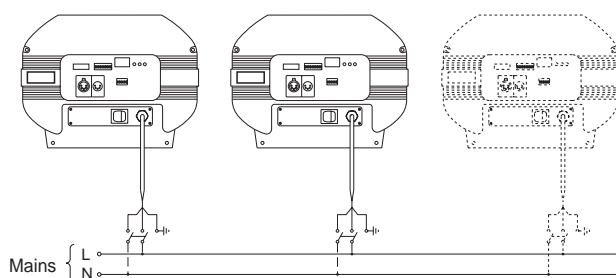

BROWN	=	L
BLUE	=	N
YELLOW	=	⊥
GREEN	=	⊥

• Connecting the control signals RS 232/423 (PMX) - DMX 512.

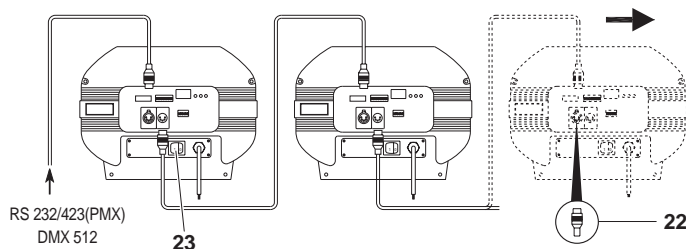

The connection between projector and control unit and between different projectors must be made with a cable conforming to the EIA RS-485 specifications: bipolar braided, shielded, 120Ω characteristic impedance, 22-24 AWG, low capacity.

IMPORTANT: Do not use microphone cable or any other cable whose specifications are different to the ones stated above.

The terminations need to be made with male/female connectors type XLR with 5 pins.

If using the DMX signal it is necessary to insert a terminal plug (22) on the last fitting with a resistance of 120Ω (minimum 1/4 W) between terminals 2 and 3.

The terminal is not needed if using the RS232/423 (PMX) signal.

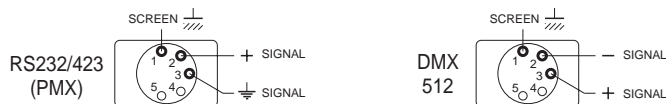

IMPORTANT: The wires must make no contact with each other or with the metal casing of the connectors. The casing needs to be connected to the braid of the shield and to pin 1 of the connectors.

• **Switching on the projector**

After carrying out all the above operations, press the switch (23) checking it all works properly.

At switch on, the software contained in the DMX Receiver microprocessor does a checksum (automatic check) while the three figure display (24) is off and the three LEDs (25) controlling the input signal are all on. After a few seconds, the projector starts the mechanical zero setting of the effects. At the same time, if the checksum has had a positive result, a code corresponding to the version of the DMX Receiver microprocessor (installed) appears on the display. This code is displayed for about 5 seconds, then only one of the three LEDs relating to the connected input signal stays on, while the following information scrolls on the display once:

Total hours - XXX Bulb hours - XXX Bulb strikes - XXX Address - XXX

in which "Total hours" is the total number of hours of the fitting's life, "Bulb hours" is the number of hours of the lamp's life, "Bulb strikes" is the number of times the lamp has been switched on and "Address" is the selected starting address for the projector control signals.

After the information has scrolled, the projector address will stay displayed.

The above information can also be displayed by carrying out at least one of the following operations:

- Setting all the DIL (Dual-In-Line) switches of the addresses (26) onto zero.
- Activating the TEST procedure, turning the specific DIL switch (27) ON.
- Setting the projector on blackout (20 channels starting from the selected starting address, all at level zero).

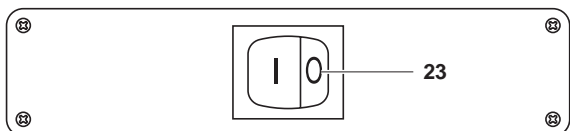
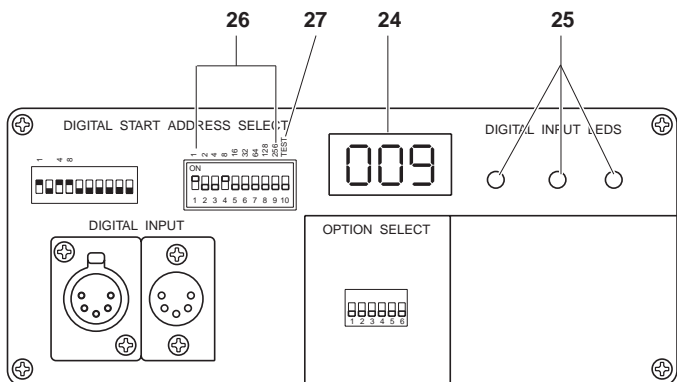

About two minutes after the projector has been switched on, the luminous intensity of the display (24) decreases to 1/32 of the maximum value. The maximum luminosity is restored automatically if you use the microswitches to select the DMX address, set the options or activate the TEST function. Approximately two minutes after the last operation listed above has ended, the luminosity of the display decreases again.

• **Projector coding**

Each GOLDEN SCAN 3 requires 6 or 8 control channels. For these to be correctly addressed to each projector it is necessary to code the projectors. This operation needs to be carried out on each GOLDEN SCAN 3 by switching the microswitches (26) according to the table below.

Codes can be assigned with the projector off, although the operation will be easier with the projector on, as the decade address corresponding to the binary code set with the microswitches is shown on the 3-digit display (24).

When the information of "Total hours", "Bulb hours", "Bulb strikes" and "Address" is scrolling on the display and you use the DIL switches of the addresses (26), the display will instantly show the new address selected. After a few seconds the above information will start scrolling again if at least one of the above conditions remains.

CODE	1	2	4	8	16	32	64	128	256	TEST
Projector 1 - Channels 1-6	ON OFF	▲ ▼	▼	▼	▼	▼	▼	▼	▼	▼
Projector 2 - Channels 7-12	ON OFF	▲	▲	▲	▼	▼	▼	▼	▼	▼
Projector 3 - Channels 13-18	ON OFF	▲	▼	▲	▲	▼	▼	▼	▼	▼
Projector 4 - Channels 19-24	ON OFF	▲	▲	▼	▼	▲	▼	▼	▼	▼
Projector 5 - Channels 25-30	ON OFF	▲	▼	▼	▲	▲	▼	▼	▼	▼
Projector 6 - Channels 31-36	ON OFF	▲	▲	▲	▲	▲	▼	▼	▼	▼
Projector 7 - Channels 37-42	ON OFF	▲	▼	▲	▼	▼	▲	▼	▼	▼
Projector 8 - Channels 43-48	ON OFF	▲	▲	▼	▲	▼	▲	▼	▼	▼
Projector 9 - Channels 49-54	ON OFF	▲	▼	▼	▼	▲	▲	▼	▼	▼
Projector 10 - Channels 55-60	ON OFF	▲	▲	▲	▼	▲	▲	▼	▼	▼
	ON OFF									▲ ▼

On turning the TEST microswitch (27) onto ON the projector runs a self-check, during which the effects are mechanically reset with the projector on. At the end of the operation, or whenever you want to interrupt this procedure, turn the TEST microswitch back onto OFF.

When sending 0% levels to all channels, the unit will start an automatic re-calibration after 2 seconds. This operation will reposition any effects to their correct settings.

The entire re-calibration cycle lasts approximately 35 seconds and can be stopped at any time by simply setting a channel at a level above 0. It is recommended not to interrupt re-calibration, but to let it end regularly, once 10 seconds have elapsed from its start.

4 MAINTENANCE

• **Opening and closing the cover**

Loosen the knob (28) and remove the re-lamping cover (18). After maintenance refit the cover (18) and lock the knob (28).

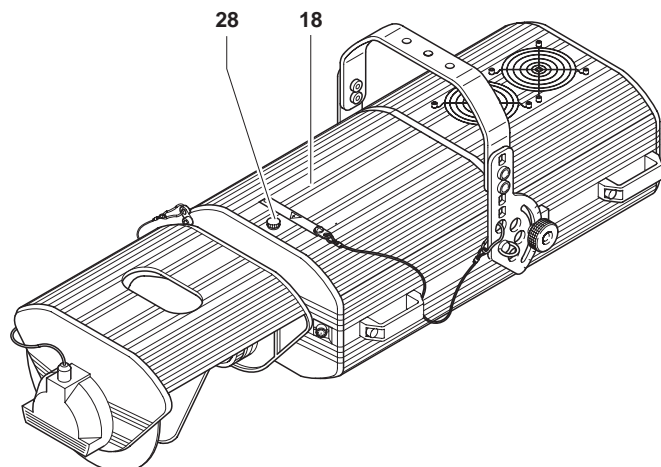

• Changing the lamp

Open the re-lamping cover, loosen the two side ring nuts (29) of the lamp to be replaced and remove it from its mountings (30).

Take the new lamp out of its package, loosen the two side ring nuts (29) and insert the lamp in its mountings (30). Finally, screw on the ring nuts.

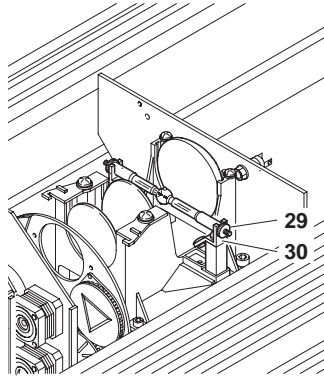

WARNING: Do not touch the lamp's bulb with bare hands. Should this happen, clean the bulb with a cloth soaked in alcohol and dry it with a clean, dry cloth.

IMPORTANT: To distribute the beam of light uniformly, the lamp needs to be positioned with the protrusion (31) visible on the bulb outside the optical axis of the projector. For this purpose it is recommended to turn the protrusion towards the top cover (18).

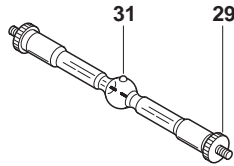

• Zero setting the working hours and number of times the lamp is switched on

To zero the hours of the lamp's life ("Bulb hours") and the number of times it is switched on ("Bulb strikes") which are stored in the DMX Receiver microprocessor, proceed as follows:

1. Set the TEST microswitch (27) to the ON position.
2. Shift the option 1 microswitch (32) from ON to OFF (or from OFF to ON) and vice versa 3 times within a time of 6 seconds. If the procedure has been carried out correctly, the three signal control LEDs (25) will light up simultaneously, while the display (24) will go completely blank. This situation lasts for approximately 5 seconds.
3. Return the TEST microswitch (27) to the OFF position.

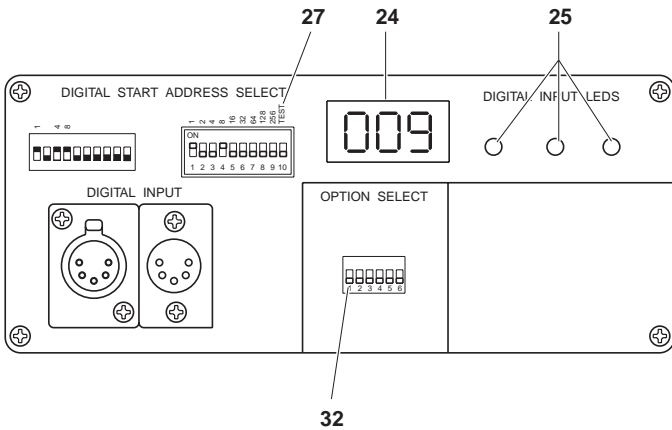

• Replacing colour filters

Find the filter to be replaced, grip it between your fingers and push it towards the movable point of anchorage (33) until the filter comes out of the fixed points of anchorage (34). Bend the filter outwards and take it out. Insert the new filter into the mobile point (33) and anchor it in the two fixed points (34).

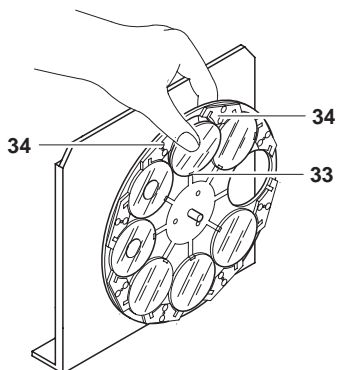

Standard colour filters:

- Red: 080301/005
- Yellow: 080301/002
- Violet: 080301/004
- Green: 080301/003
- Orange: 080301/007
- Blue: 080301/001
- Pink: 080301/006

• Replacing metal gobos

Find the gobo to be replaced and delicately press towards the anchorage points (35) until the gobo comes out.

Take the selected replacement from the holder (36) on the dimmer/stopper/strobe plate. To insert the new gobo, position it at the two points of anchorage (35) and, lightly pressing it, slot it into the remaining points, verifying the levelness of the gobo in its housing.

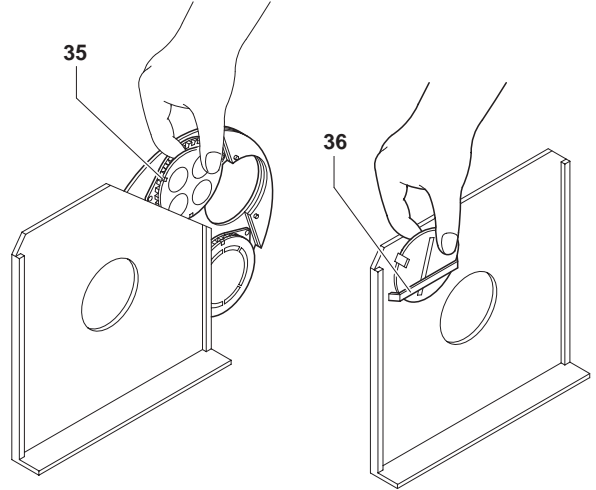

STANDARD GOBOS

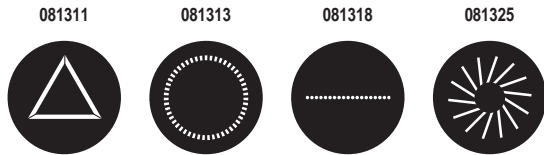

OPTIONAL GOBOS

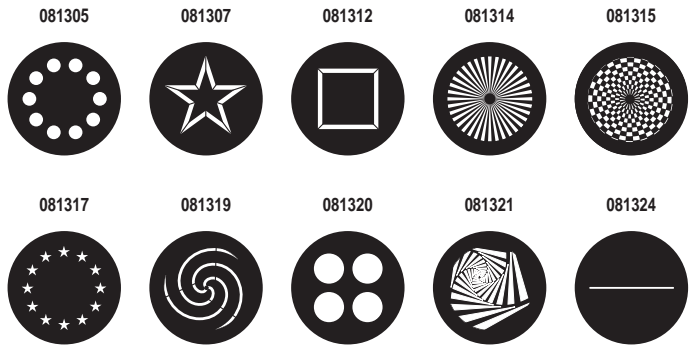

• Lubrication of rotating gobos

To ensure that the rotating gobos continue to operate smoothly, the bearings should be lubricated with oil every six months: use only Kernite LUBE-K-AHT (code 164028/801).

Apply the oil using a syringe with a fine needle.

Avoid over-lubricating, as excess oil could be splattered during rotation.

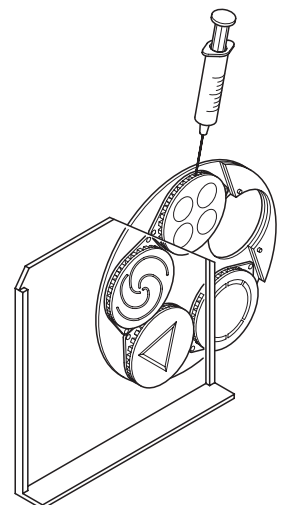

• Periodical cleaning

To keep optimum efficiency and functionality over time, it is vital to periodically clean the parts where dust and grease can accumulate.

The frequency with which to carry out the following operations depends on several factors, such as the number of movements of the effects and the quality of the work environment (air humidity, dustiness, saltiness, etc.).

To remove dirt from the lenses and filters, use a soft cloth dampened with any liquid detergent for cleaning glass.

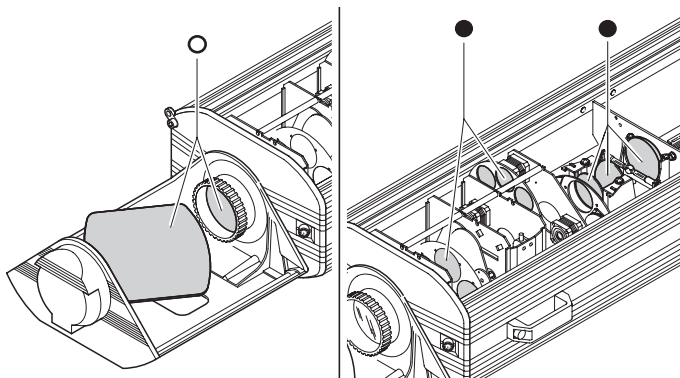

Never use solvents or spirits.

- Parts requiring frequent cleaning.
- Parts requiring monthly cleaning.

Once a year it is recommended to submit the projector to qualified technical personnel for non-routine maintenance consisting of at least the following operations:

- General cleaning of internal parts.
- Restoring lubrication of all parts subject to friction, using lubricants specifically supplied by Clay Paky.
- General inspection of internal components, wiring, mechanical parts, etc.
- Electrical, photometric and functional tests.
- Any repairs.

5 TROUBLE SHOOTING

THE PROJECTOR WILL NOT SWITCH ON			TROUBLE
THE ELECTRONICS DO NOT WORK			
DEFECTIVE PROJECTION			
REDUCED BRIGHTNESS			
	POSSIBLE CAUSES	CHECKS AND REMEDIES	
●	No mains supply.	Check there is power at the supply socket.	
●	Lamp exhausted or defective.	Replace the lamp (see instructions).	●
●	Signal transmission cable short-circuited or disconnected.	Replace cables.	
●	Wrong coding.	Check coding (see instructions).	
●	Defect in electronic circuits.	Call an authorized technician.	
	Lenses or reflector broken.	Call an authorized technician.	●
	Dust or grease deposited.	Clean (see instructions).	● ●

6 TECHNICAL DATA

Power supply available

- 230V 50Hz
- 240V 50Hz
- 208V 60Hz
- 200V 50Hz
- 200V 60Hz

The projector is designed to operate at mains frequency and voltage given on the electrical data label on the back of the appliance.

Lamp

Metal halide type supplied with special built-in power supply unit.

- Type HMI 1200W/GS
 - Cap SFc 15,5-6
 - Colour temperature 6.000 K
 - Luminous flux 110.000 lm
 - Average life 750 h
 - Any working position
- Type HMI 575W
 - Cap SFc 10-4
 - Colour temperature 6.000 K
 - Luminous flux 49.000 lm
 - Average life 750 h
 - Any working position

Input power

- HMI 1200 Touring Version: 1500VA at 220V 50Hz (correction factor 140µF standard)
- HMI 1200 Version: 3000VA at 220V 50Hz
- HMI 575 Version: 1500 VA at 220V 50Hz

Motors

9 stepper motors, operating with micro-steps, totally microprocessor controlled.

Optical unit

- Base in die-cast aluminium.
- Twin lens condenser.
- Spherical reflector with a high luminous efficiency.

Lens unit

- Standard: 1:2,5/250 mm.
- Optional: 1:3,3/300 mm.
- Optional: 1:1,6/160 mm (to be fitted internally of projector).

Channels

6 control channels (normal operation) or 8 control channels (extended operation)

Inputs

- RS232/423 (PMX).
- DMX 512.

Rotating mirror head

- Head rotatable through 360° on projector housing.
- Graduated scale for easy and accurate positioning.
- Anchorage for safety wire.
- Mirror of ultra-high luminous efficiency.
- Movement by means of three stepper motors, controlled by microprocessor.
- Travel:
 - PAN = 150°
 - TILT = 110°
- Speed:
 - PAN = 0,4 sec (150°)
 - TILT = 0,3 sec (110°)
- Resolution:
 - PAN = 0.6° (150°)
 - TILT = 0.4° (110°)

Safety Devices

- Bipolar circuit breaker with thermal protection.
- Automatic break in power supply in case of overheating or failed operation of cooling system.
- Automatic disconnection of the power supply at the opening of the re-lamping cover.
- Two fixing points for safety rope.

Cooling

Forced ventilation with axial fans.

Body

- In die-cast and extruded aluminium.
- Epoxy powder painting.
- Four side handles for transportation (standard feature on Touring Version only).

Support

- Steel bracket with epoxy powder painting.
- Six installation positions, 25mm (1") apart.
- Bracket adjustable through 100° with graduated scale to assist positioning.

Working position

Operation in any position.

Weights and dimensions

- HMI 1200 TV: 36.4 kg (80 lbs 1 ozs)
- HMI 1200: 35.5 kg (78 lbs 2 ozs)
- HMI 575: 29.5 kg (64 lbs 14 ozs)
- Mirror head: 3.1 kg (6 lbs 13 ozs)

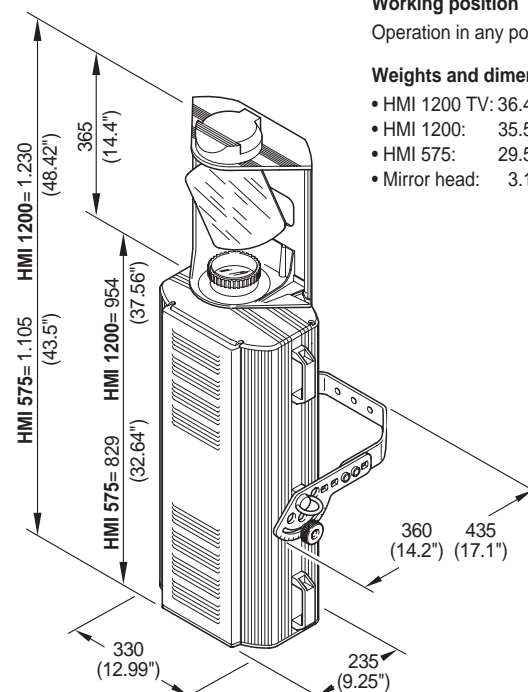

**ACCESSORI OPZIONALI
OPTIONAL ACCESSORIES
ACCESSOIRES OPTIONNELS
OPTIONALE ZUBEHÖRTEILE
ACCESORIOS OPCIONALES**

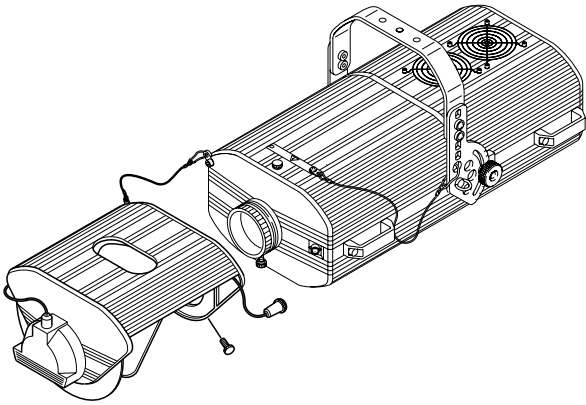

C21061

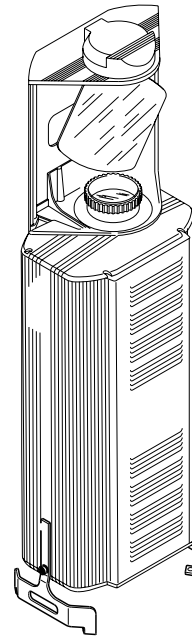

C21029